

Passionate about Particulate

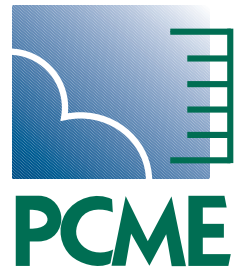

Leak Alert 75

ELECTRODYNAMIC™
INSIDE

Dust

Leak

Monitors

TUV approved
Filter Leak
Monitor**
*approval pending



*shown with optional external keypad

- Designed to differentiate between gross failure and dust leakage from faulty/failing filter systems including bag filters
- Automatic internal zero and reference self-checks for regulatory compliance
- Selection of advanced features and options for improved performance
- Increased quality assurance over previous models



Certificate No: 9389

applications

System Description and Product Range

The Leak Alert 75 is particularly suited for use on fabric filter type dust collectors (baghouses) and provides reliable and robust monitoring of particulate leaks from bags. With its compact cost effective transmitter design, pragmatic reliable monitoring can now be provided for all types of industrial bagfilters. The instrument benefits, first from PCME's unique *ElectroDynamic™* Probe Electrification technology, secondly advanced features enabling the Leak Alert 75 to be configured for all types of bagfilters irrespective of cleaning sequence and finally an external display and self check option which provides added quality control. The Leak Alert 75 exceeds the requirements for a bag leak detector under EU regulatory compliance.



Principles of Operation

The Leak Alert 75 combines advanced signal processing techniques with PCME's unique *ElectroDynamic™* Probe Electrification technology. When the sensing probe is installed after the bagfilter, particles in the airstream interact with the sensing rod to induce a charge signature. The resulting signal is filtered electronically to reject signals outside a defined frequency range (including the dc Triboelectric signal) which makes the instrument less susceptible to changes in particle velocity and to virtually eliminate the effect of any particle contamination on the rod. In bagfilter applications the instrument provides a robust signal proportional to dust emissions which is used to monitor and detect bag leaks. The instrument has the necessary features to discriminate between the variation in dust due to the bag cleaning sequence and real leak conditions.

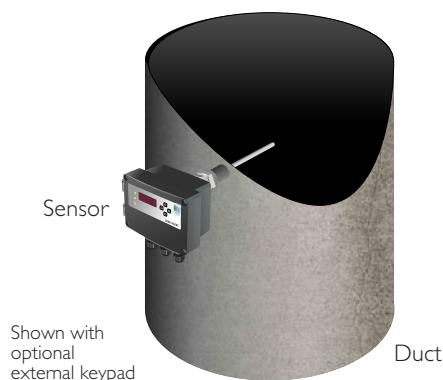

Instrument Performance Approvals



In addition to providing leak location capability, the LeakAlert 75 is designed to meet all performance approvals as a "Dust Filter Leak Monitor" and relevant product approvals for dust filter leak location according to European and ASTM standards. The product has TÜV approval as a filter leak monitor (BlmSchV 27 approval) as a filter leak monitor and is suitable for meeting ASTM D 6023-03 for bag leak monitors. The instrument is provided with internal zero and reference Quality Assurance features required to meet these standards, saving the user considerable time in performing alternative manual procedures.

Advanced Features

The Leak Alert 75 provides powerful bagleak capability based on the following standard features:

Bag leak monitoring performance

- High quality leak response with sufficient dynamic range and time response to track emissions from single and multi-compartment pulse cleaned bagfilters
- Instrument drift and minimum detection level below 0.1 mg/m^3 with leak monitoring to 500 mg/m^3
- Fully configurable warning alarm and limit alarm levels with independent alarm delay
- Convenient bag leak output range in defined units (user selectable)

Designed for practical bagfilter issues

- Category 3 option is suitable for ATEX dust zone 22 (see Category 1 option for zones 20 and 21)
- Inbuilt surge protection to counter effects of indirect lightning
- Instrument connector may be used for marker Pulse from bag cleaning cycle
- Industrially hardened enclosure and sensor mechanics provides convenient connections to plant allowing armoured cable use
- Powered directly from mains power supply 110/230VAC or (24VDC option)

Powerful user Interface

- External 4 digit display
- Instrument set-up via internal keypad or PC laptop (optional software required)
- Options for external keypad
- Intuitive multilevel user interface (user set-up, engineering set-up) with password protection
- Three separate tri colour status LEDs, for power, emission alarms and instrument self-checks

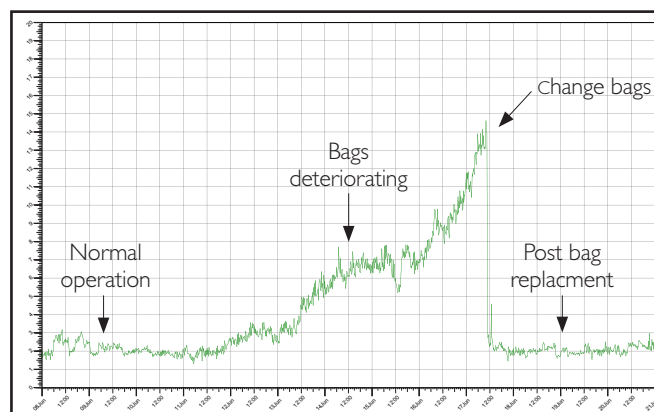

Leak Alert Monitors Bag Leak Conditions



Leak Alert 75 showing external keypad (option) and internal keypad

specifications

User selectable added value options

The Leak Alert 75 provided with a full choice of user selectable added value features. These include:



- **Automatic insulator contamination detection - option**

Electrodynamic sensors are tolerant to dust contamination of the sensor rod (unlike Triboelectric systems) due to the non-contact measurement principle, however; build-up of conductive material across the insulator at the base of the rod can lead to error (as with all charge electrification systems). For standard dry dust collector applications, contamination is unlikely, but a possibility. The detection option provides a reliable method for detecting insulator contamination and hence improve Quality Assurance. (for applications where water condensation is likely, PCME's patented insulated sensor is a preferred option).

- **Electronics zero and reference drift detection - included as standard feature**

Simulated dust signals are injected into the front end of the sensor electronics to ensure any electronic and signal measurement malfunction is automatically detected. This Quality Assurance Feature is required by European and ASTM (US) performance standards for Filter Leak monitors. This feature is controlled manually (standard) or automatically (option).

- **User scaling of display - included as standard feature**

The instrument can be specified with a choice of two forms of user scaling providing assistance to plant personnel wishing to manually scale the display to an approximate known dust level or those wishing to display emissions relative to a 100% full scale

Specifications

Feature	Specification
Ambient air temperature (stack limit is 250°C or 400°C)	-25°C to +55°C 250°C standard, 400°C option
Stack connection (at sensor connection)	1 1/2" BSP
Enclosure rating	IP-65 (with hinged lid closed)
Power Requirements	110/230VAC 50/60Hz (32mA) or 24VDC (300mA)
Outputs (Standard)	Isolated 4-20mA (500 ohm) Warning alarm relay (SPST 1A@24VDC) Fail safe Emission alarm relay (SPST 1A@24VDC) Fail safe
Outputs (Optional)	RS-232 output - option RS-485 (Modbus) - option
Inputs	Plant stop signal (output to zero when plant is off), marker for start of bag cleaning sequence
External LED x3	1 Power/ sensor OK 2 Warning and limit alarm 3 Self check status (options)
User set up	4 digit display and set up buttons
Cable entries	3 x M20 gland/conduit entries
Air purge connection	1/4" BSP*

*option: requires external supply of 5-10 litres/min of dry, clean, oil free instrument air depending on dust loading.

Upgrade path to Leak Locate 880

The Leak Alert 75 may be upgraded to the Leak Locate 880 instrument. This enables plant operators to locate the position of failing bag rows in the dust collector, hence reducing bag replacement costs and minimising the time diagnosing dust collector faults.

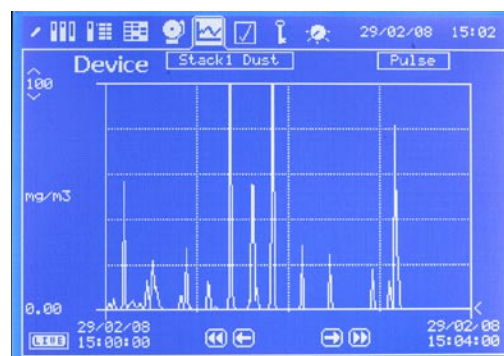

Screen showing bag cleaning cycle

specifications

Physical Dimensions & Duct Connection

Back Display

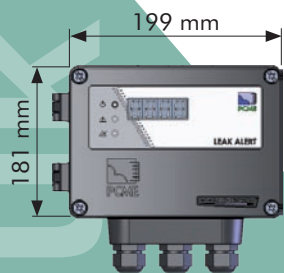

Back Display with External Keypad

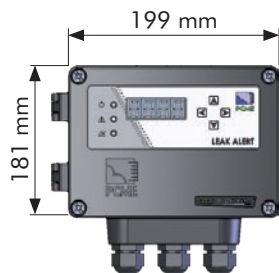

Duct Connection

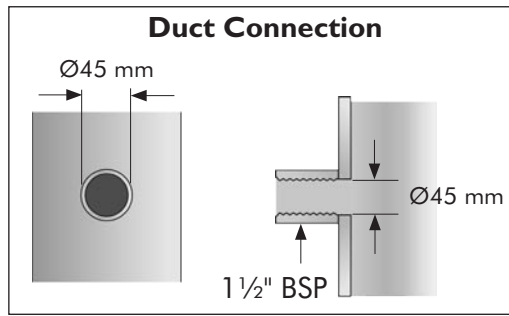

250°C Stainless steel

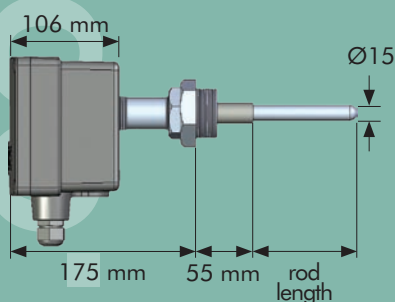

250°C Insulated

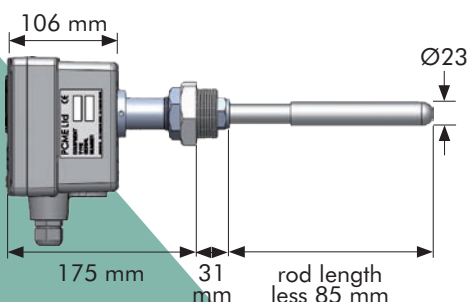

400°C Stainless steel

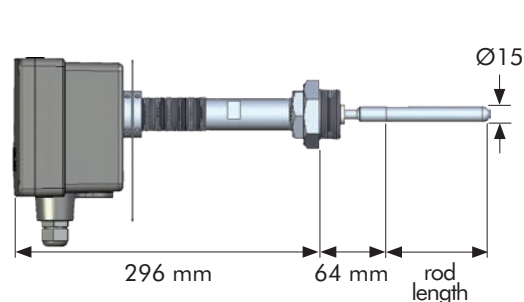

Order Codes

LeakAlert 75 - I 2 3 4 5 / A B C D E F G H I J

Example: LeakAlert 75 -

I	2	3	4	5	A	B	C	D	E	F	G	H	I	J
250C	ROD0500	S	AP	REG	SC	MAN	SF	X22	AC	485	0	0	IK	ED

Mechanical Options (I2345)

I	2	3	4	5
Stack Temperature	Rod Length	Rod material	Air Purge Fitting	Air Filter/Regulator
Up to 250°C Up to 400°C	0100mm to 1000mm	Stainless Insulated (PTFE)	None Air purge fitting	None Filter + regulator assembly
Standard Option	Standard	Standard Option	Standard Option	Standard Option
250C 400C	RODxxxx	S I	0 AP	0 REG

Sensor Features (A B C D E F G H I J)

A	B	C	D	E	F	G	H	I	J
Contamination check	Electronic self-checks	Scaling Method	ATEX category	Power option	RS485 Data output	RS232 Data output	External Connector for RS232	Keypad	Display
None Short Circuit Check*	Manually initiated Automatic	Scaling factor 0-100%	None Category 3 dust (zone 22) Category 1 dust (zone 20)	115/230V AC 24V DC	Not included RS485 included	Not included RS232 included	Internal connector External connector	Internal keypad External keypad	Externally viewable
Standard Option	Standard Option	Standard Option	Standard Option Option	Standard Option	Standard Option	Standard Option	Standard Option	Standard Option	Standard
0 SC	MAN AUTO	SF %	0 X22 X20	AC 24DC	0 485	0 232	0 FLY	IK EK	ED

Optional PC Software

Configuration	For instrument configuration by PC
PCView*	For viewing emissions on PC

*requires RS232 output or RS485 option

*not available with insulated rod material

About PCME Ltd

As a progressive environmental Company, PCME specialises in particulate measurement for industrial processes. With a worldwide reputation for reliability, innovation and technological excellence, the Company produces equipment for concentration and mass monitoring for regulatory, environmental and process control requirements. A dedicated team of qualified application and sales engineers is always on hand and should be consulted in the selection and usage of the most suitable equipment for any particulate application.



PCME Ltd
 Clearview Building, 60 Edison Road
 St. Ives, Cambs PE27 3GH UK
 Tel: Int +44 (0)1480 468200
 Fax: Int +44 (0)1480 463400
 E-mail: sales@pcme.co.uk

Contact your national or area sales and service office